



CHARLESTON LEVEL RAIL INSTRUCTIONS

Always check your local building codes before starting a project. Please read assembly instructions completely before beginning construction. Always wear protective goggles & gloves when installing a railing system.

TOOLS REQUIRED

- Protective eye glasses
- Tape measure
- Variable speed drill/screwdriver
- Phillips Driver and #2 Square Driver
- Rotary hammer or Hammer Drill and 1/2" masonry percussion bit (for concrete installations)
- Drill bits 1/4", 5/32", 3/32"
- Wrench and 3/4" deep socket
- PVC Glue
- Miter Saw
- Level (min 24") and small torpedo level
- Snap Line

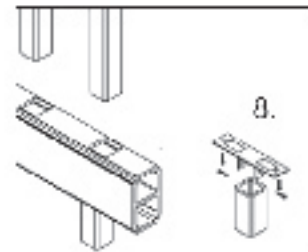
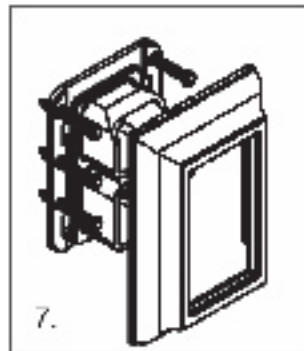
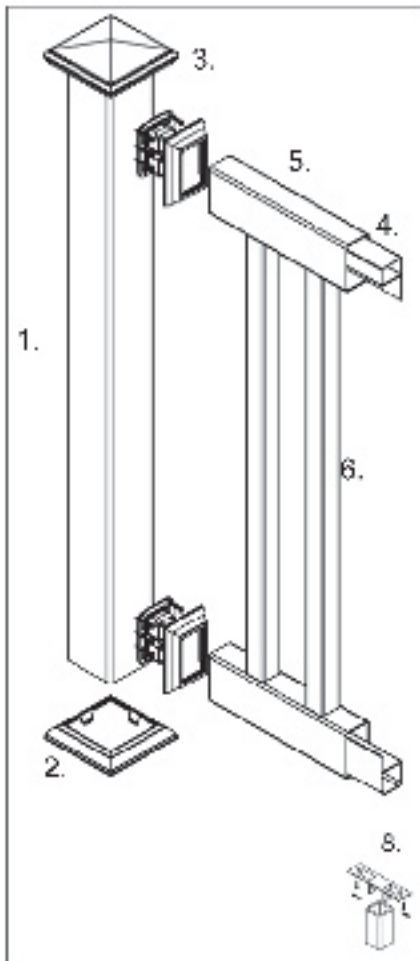

STANDARD RAIL COMPONENTS

1. 4" x 4" Post
2. 4" x 4" Post Trim
3. 4" x 4" Post Cap
4. Aluminum P-Channel
5. 2" x 3 1/2" Charleston Rail
6. 1 1/2" x 1 1/2" Pickets or Spindles
7. 2" x 3 1/2" Rail Trim and Bracket
8. Foot Block

LAYOUT

The Railing Systems are designed for posts sets of either 48" (4 feet), 72" (6 feet), 96" (8 feet), or 120" (10 feet) on center as shown in Figure 1. The vinyl rail and aluminum inserts can be trimmed simultaneously to shorter lengths using a hacksaw. When trimming of the rails is necessary, equal amounts should be cut from both ends of the rails in order to maintain equal spacing from the outer picket and the adjacent posts.

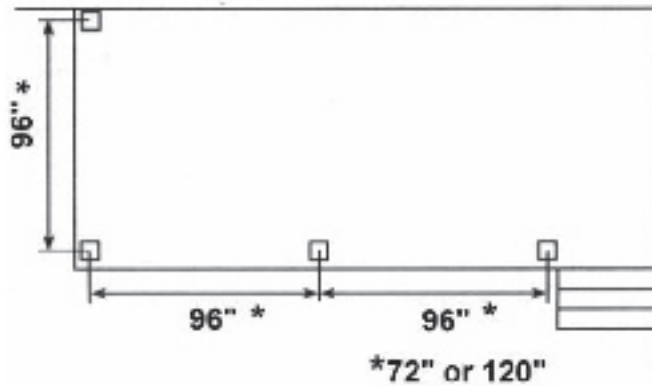

Figure 1. Post Layout

Determine ahead of time if the post will be anchored to the top of the deck substructure, bolted to the inside or the outside of the deck joists, or anchored in concrete. Refer to instructions included with the side mount kits or surface mount kits for installation.

It is best to do a sketch of the general layout in order to plan for post locations and any adjustments to rail lengths. (See Figures 2 and 3 for examples of non-level deck surfaces.) Check measurements for accuracy prior to beginning the actual installation. Remember, when sleeving existing wood posts, the outside dimensions of the PVC post sleeve is 4", unlike wood, which is 3¹/₂" to 3⁵/₈". The rail height must be at least 36" above the deck/porch surface, and in some areas 42" is required. Check local building codes for rail height requirements in your area. The bottom rail is designed to be 2¹/₂" above the surface. This can be lowered, but the post trim must be notched to accommodate the rail trim and the 2¹/₂" foot block must also be trimmed to desired length.

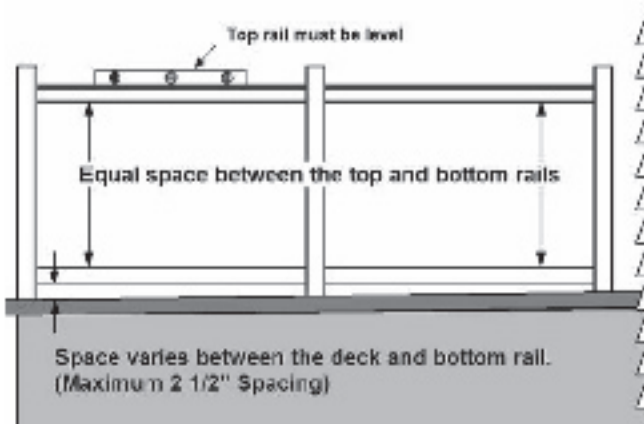

Figure 2. Compensating for a Sloping Deck

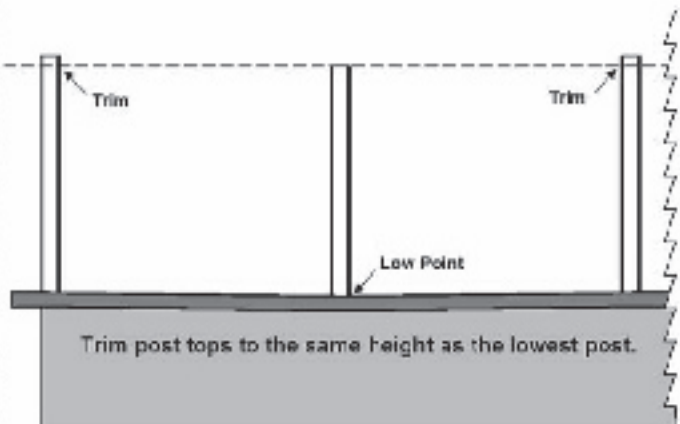
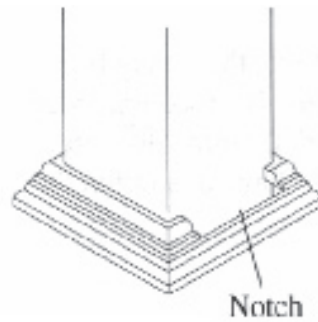

Figure 3. Compensating for a Low Point.

Figure 4. Notch Required if Bottom Rail is Less Than 2½" from Deck Surface



POST INSTALLATION

Posts can be bolted to the inside or the outside of the deck joists, surface-mounted to the substructure, or surface-mounted to a concrete slab (Figure 5.). A wood 4 x 4 may be used for side mount applications as shown in Figure 5a. Aluminum post tower insert kits are available for surface mounts. Surface mount kits (Figures 5b and 5c) are available for systems up to 36" high ("residential") and up to 42" high ("commercial"). Refer to your instructions included in the tower kits for the proper installation.

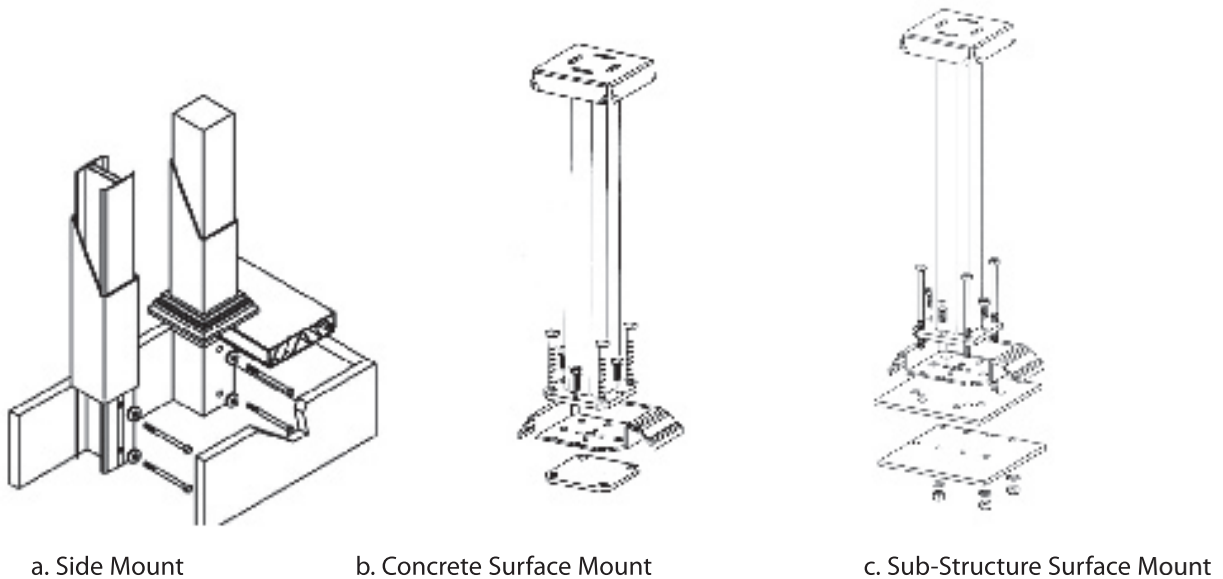

Figure 5. Post Installation Options

Once post installation is complete, trim the post sleeve to the proper length and slide over the wood or aluminum mount. Make certain that you maintain an installed vinyl post length as measured from the walking surface to the top of the post that is at least 3" greater than the required rail height:

HORIZONTAL RAIL INSTALLATION

The custom brackets are designed for easy installation and to provide the required support needed to meet building codes. Prior to completion of these steps, ensure that you complete the post installations as described above.

1.) Cut Rails and Inserts to Length. Measure distance between the inside of the top of the posts and subtract ½" to allow room for brackets. This is the length of the top rail. Measure the distance between the posts close to the bottom and subtract ½" to allow room for the bottom brackets. This is the length of your bottom 2" x 3½" rail. Trim the rails and the aluminum inserts to these determined lengths.

The insert should be the same length as its respective rail. **IMPORTANT:** Trim both ends of the rails to maintain the uniform picket spacing, with pickets equally spaced between posts. Do not leave an open picket insert hole at the bracket.

- 2.) Install Post Trim. Be sure you install the post trim over the posts before you start attaching the stair rail sections to the posts.
- 3.) Drill Drain Holes. Take the 2" x 3½" rail and drill three ¼" drain holes on the underside of the bottom rail as shown in Figure 6.

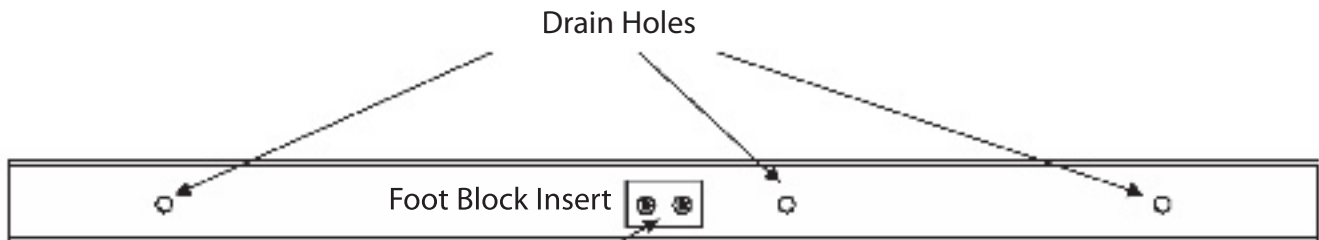

Figure 6. Drain Hole Locations (Bottom of Bottom Rail).

- 4.) Install Aluminum Insert (if required) and Install Foot Block Inserts. Slide in an aluminum insert into the 2" x 3½" bottom rail so that they will be in the orientation as shown in Figure 7 when installed. Center and screw one foot block insert onto the bottom of the bottom rail and another insert in between the posts on the walking surface as shown in Figure 8.

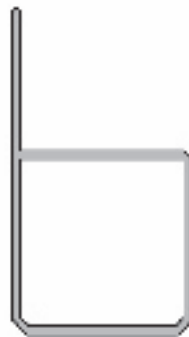

Figure 7. Aluminum Insert Orientation

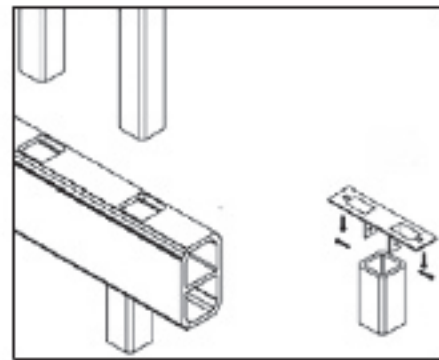

Figure 8. Foot Block Installation

- 5.) Install Bottom Brackets: Slide trim pieces onto the bottom rail facing the finished trim towards the center of the rail. After making certain that the aluminum insert is positioned with the shorter legs facing the hole, insert the 2" x 3½" brackets at both ends the bottom rail. Lower bottom rail (the rail with your drain holes) into position between posts and set onto the foot block (Figure 9). Make sure the holes for the pickets are facing up. Ensure the rail is level and the bracket is centered on the post. Attach bracket to the post using 6 screws provided for each bracket (Figure 10). Drive one of the smaller screws provided through the top of the rail ⅜" of an inch from the post down into the bracket. This will provide the mechanical attachment of the rail to the bracket.

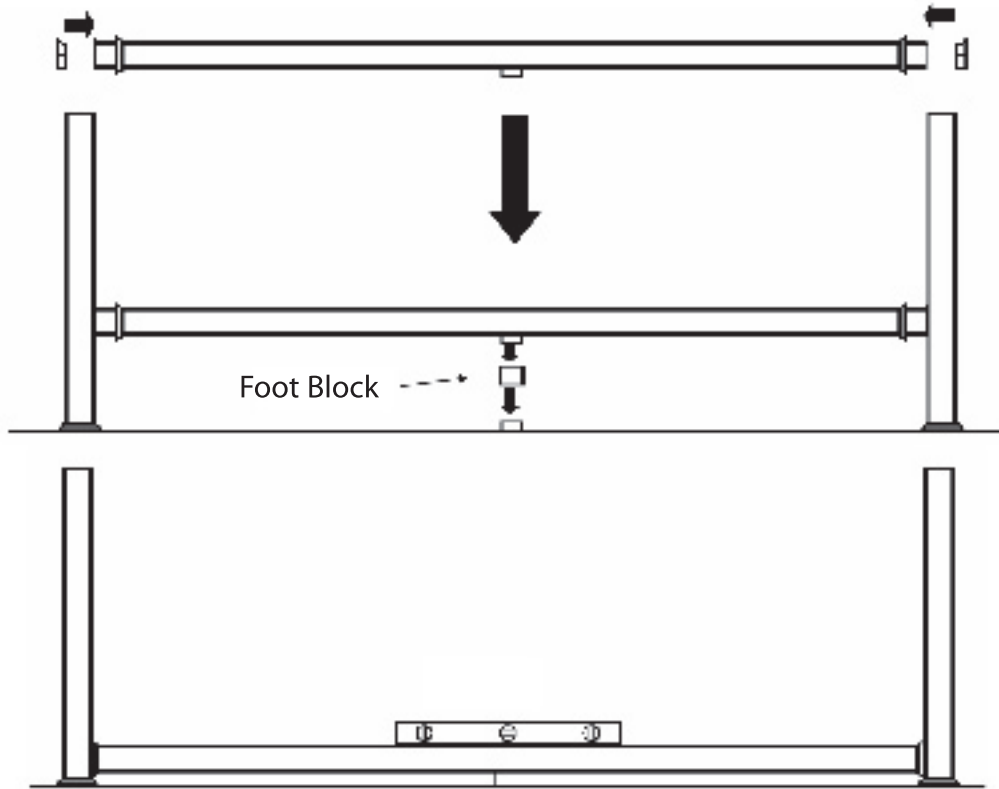

Figure 9. Bottom Rail in Position

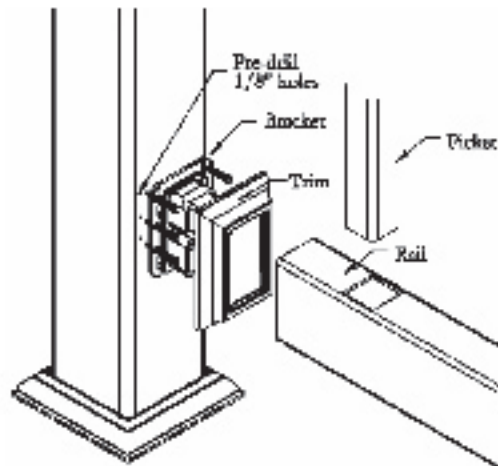

Figure 10. Installation of Bottom Bracket

- 6.) Install Top Brackets Rail. Insert the aluminum insert into the rail in the orientation shown in Figure 11. Place a bracket at the end each rail. Slide trim pieces onto the rail facing the finished trim towards the center of the rail. Insert the remaining pickets or spindles in to the bottom rail. Starting at one end of the rail begin feeding the rail down onto the pickets or spindles. Once the top of the rail has been seated onto all the pickets and the rail is level install the bracket following the same procedure as Step 5.

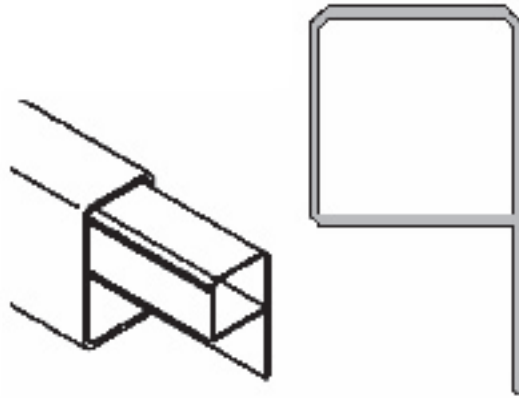

Figure 11. Aluminum Insert Orientation for the Top Rail

- 7.) Install Post Cap. Place a 1" x 1/4" wide bead of glue on inside of cap along the center of all four sides. Slide cap onto top of post. The tabs will smear the glue as the cap is slid on the post and a permanent bond will take effect after a few minutes. Be careful not to drip glue on the outside of a post or cap or it will cause a "scar" in the PVC.

FINISHING TOUCHES TO PVC RAILING

Generally, no cleaning is required under normal circumstances. If cleaning becomes necessary, use a mild detergent or household cleaner. If stains or scuff marks appear, use a fiberglass cleaner/glaze or #0000 steel wool and Simple Green™. The surface can be sanded, and a fine sand paper (such as 200 grit) should be used, followed by 400 or 600 grit to polish and restore it to its original finish.

It is the responsibility of the decking contractor to meet or exceed all code and safety requirements, and to obtain all required building permits. These instructions are only a guide, and may not address every circumstance. The deck and railing installer should determine and implement appropriate installation techniques for each situation. The manufacturer shall not be held liable for improper or unsafe installations.



1.800.783.2179
www.homescapefdr.com